



Metropolitan Ceramics®

QUARRY TILE

Designed for *Demanding Applications*



METROPOLITAN®
C E R A M I C S

Ironrock Since 1866

www.metroceramics.com



Natural Slip Resistance

Metropolitan Ceramics' QuarryBasics® product lines provide dependable flooring options with a matte finish, a range of desirable colors, and a naturally slip resisting surface. The perfect combination for high traffic multi-use commercial and residential design needs.

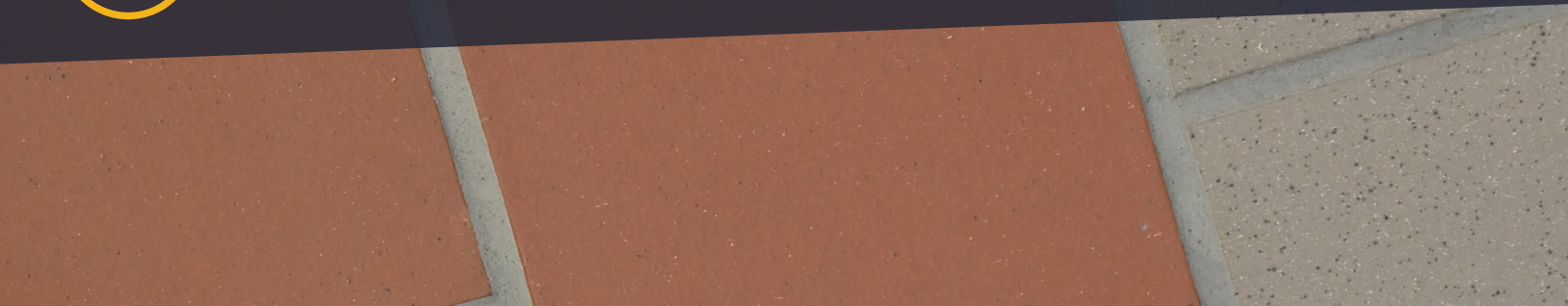

QuarryBasics® Ironspot

QuarryBasics® Ironspot is a durable matte finish tile with a subtle through-body salt and pepper appearance. Available in three popular colors, and designed with a focus on heavy use, functionality and visual appeal in mind, QuarryBasics® Ironspot stands out as the preferred choice for demanding projects.



15IS Buckskin

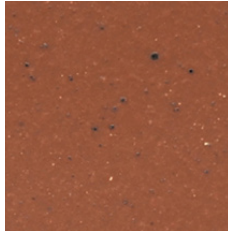

31IS Mayflower Red

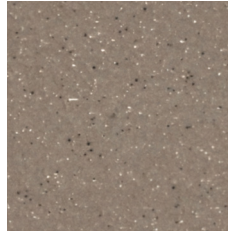

57IS Puritan Gray

Available Sizes	4"x 8"	6"x 6"	8"x 8"
15IS Buckskin	-	✓	✓
31IS Mayflower Red	-	✓	✓
57IS Puritan Gray	-	✓	✓

QuarryBasics® Clear Tones

A reliable flooring solution designed for demanding environments, these durable quarry floor tiles are vitreous, rendering them suitable for both indoor and outdoor use in any climate. QuarryBasics® Clear Tones, known for their ease of maintenance and resistance to impact and abrasion, make them an excellent choice for both commercial and residential applications.

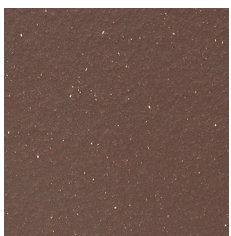

108 Chestnut Brown

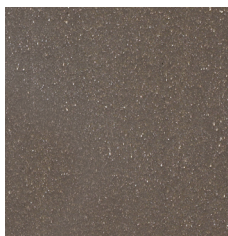

705 Pewter
(Premium Color)



710 Raven
(Premium Color)

Available Sizes	4"x 8"	6"x 6"	8"x 8"
108 Chestnut Brown	-	✓	-
705 Pewter	-	✓	-
710 Raven	✓	✓	✓

Added Slip Resistance

Metropolitan Ceramics' added slip resistance product lines provide enhanced grip, designed for the most demanding commercial environments.

XA-Abrasive™

Two Slip Resisting Additives

XA-Abrasive combines two slip resisting additives to create a one-of-a-kind slip resisting tile with a Dynamic Coefficient of Friction ≥ 0.70 .

With XA-Abrasive, the properties of both QuarryBasics® X-Colors and QuarryBasics® Abrasive are incorporated into one tile. The silicon embedded surface, combined with the metallic additive through the body of the tile, work together to combat the effects of spills, moisture, extreme temperatures and heavy traffic.

Use XA-Abrasive™ in the most demanding environments and anywhere durability and slip resistance are important.

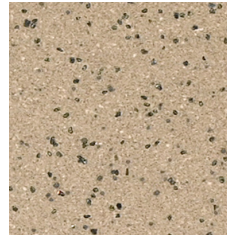

15XA Buckskin

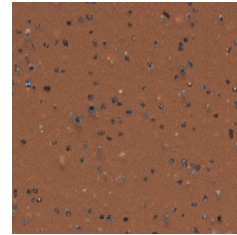

31XA Mayflower Red

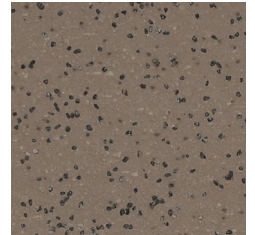

57XA Puritan Gray

Available Sizes

4"x 8"

6"x 6"

8"x 8"

	4"x 8"	6"x 6"	8"x 8"
15XA Buckskin	-	✓	✓
31XA Mayflower Red	-	✓	✓
57XA Puritan Gray	-	✓	✓



Please Note: Colors are as accurate as printed representations can be. For final color selection refer to current actual color samples.

SAFETY
DURABILITY



METRO Tread® Raised Treads



METRO Tread® features nine raised treads across the surface of each tile and spaced 5/8" apart for added slip resistance. METRO Tread® is a popular choice for commercial kitchens and anywhere slip resistance is a concern.

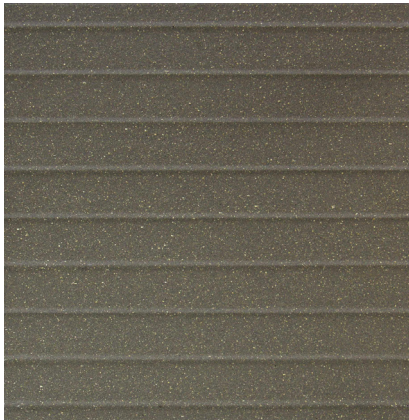

75T Pewter
(Premium Color)

Available Size | 6" x 6"

Installation Patterns

METRO Tread® must be installed in one of two patterns depending on the application.

Grid Pattern

For use in multi-directional traffic such as commercial kitchens.

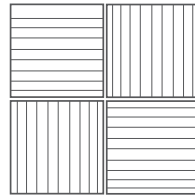

Linear Pattern

When traffic flows across the tread such as in a hallway or ramp.



Down to Earth® Flashed/ Textured Tile

Paver tiles offer rich natural color variation, detailed textures, and a classic shape. Down to Earth® can be used in both traditional and contemporary settings. Use a contrasting grout color to enhance the appearance of the textured surface. Use a similar grout color to minimize the texture's appearance.



155 Cobblestone



255 Desert Floor



350 Red Paver



458 Bedrock

Available in nominal
4" x 8" Size

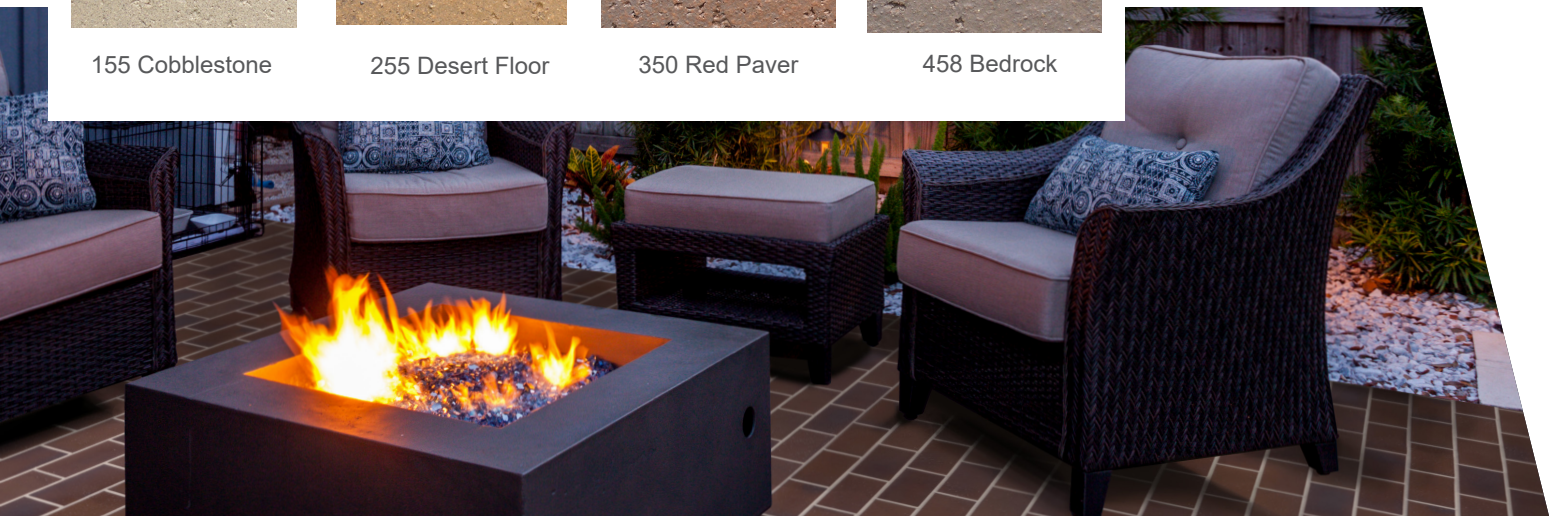

Available Sizes

All sizes are 1/2" thick. See chart for availability details.

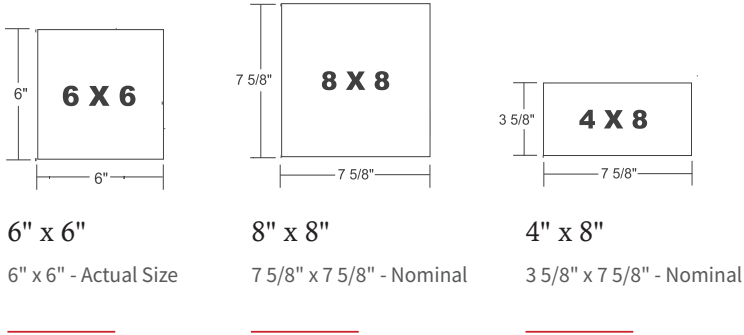

Available Trim

Trim is available in corresponding QuarryBasics® Clear Tones and QuarryBasics® Ironspot colors. Use Ironspot trim for XA-Abrasive™ colors.

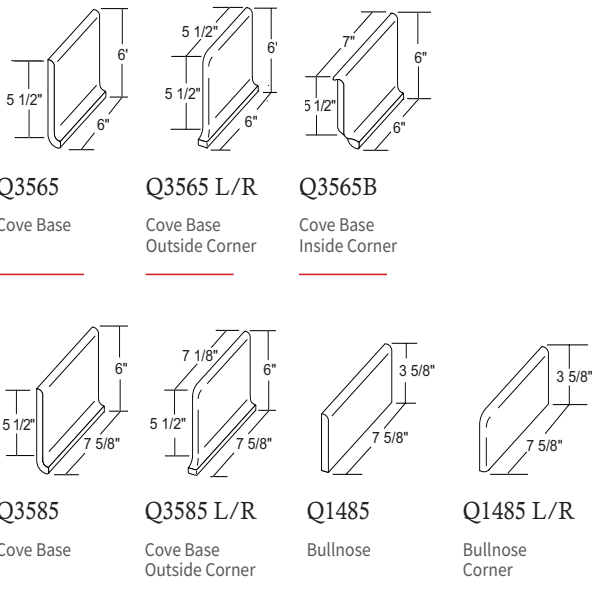

Colors & Sizes	4" x 8"	6" x 6"	8" x 8"
QuarryBasics® Clear Tones Corresponding trim available: Clear Tones			
108 Chestnut Brown	-	✓	-
705 Pewter (Premium Color)	-		-
710 Raven (Premium Color)	✓	✓	✓
QuarryBasics® Ironspot Corresponding trim available: Ironspot			
15IS Buckskin	-	✓	✓
31IS Mayflower Red	-	✓	✓
57IS Puritan Gray	-	✓	✓
XA-Abrasive™ Corresponding trim available: Ironspot			
15XA Buckskin	-	✓	✓
31XA Mayflower Red	-	✓	✓
57XA Puritan Gray	-	✓	✓
METRO Tread® Corresponding trim available: Clear Tones			
75T Pewter (Premium Color)	-	✓	-
Down to Earth® (No corresponding trim available)			
155 Cobblestone	✓	-	-
255 Desert Floor	✓	-	-
350 Red Paver	✓	-	-
458 Bedrock	✓	-	-

Shade Variation

QuarryBasics® Clear Tones

V2 | Slight Variation

QuarryBasics® Ironspot

V2 | Slight Variation

XA-Abrasive™

V2 | Slight Variation

METRO Tread®

V2 | Slight Variation

Down to Earth®

V3 | Moderate Shade Variation

Metropolitan Ceramics & The Environment

Metropolitan Ceramics® & LEED V4

Ironrock has been a member of the United States Green Building Council (USGBC) since September 2006. We are dedicated to manufacturing products that fit the requirements of LEED V4. See metroceramics.com for a complete overview of Metropolitan Ceramics and LEED.

Environmental Impact & Stewardship

Ironrock is committed to providing our customers with sustainable products while keeping with the company's commitment to good stewardship toward the environment and our community. This page gives more insight into the steps we are taking to save resources and energy in the manufacture of Metropolitan Ceramics' quarry tile and thin brick products.

We will also look at the positive environmental impact Metropolitan Ceramics' quarry tile products have once installed, for the life of their use and beyond. We will look at testing for durability, product life cycle, indoor air quality and recycled content.

Cleaning & Maintenance

The secret to a successful tile maintenance program is to begin with a clean surface. It should be the responsibility of the tile installer to thoroughly clean and remove all the grout residue and the dulling film inherent in the installation process. After initial clean up, a period of 28 days should be allowed for proper curing and maximum grout hardness.

Prior to this period, it is recommended that the installer mop the floor with a temporary coating solution of a neutral chemical cleaner in a ratio of one part cleaner to one part water. Neutral chemical cleaners both clean and enhance the natural soil-resisting character of Metropolitan Ceramics unglazed quarry tile. See our web site for complete downloadable cleaning and maintenance information.

Recycled Content

The following chart contains percentages of pre-consumer recycled material in Metropolitan Ceramics products.

QuarryBasics® Clear Tones

108 Chestnut Brown	18%
705 Pewter	23%
710 Raven	22%

QuarryBasics® Ironspot

15IS Buckskin	23%
31IS Mayflower Red	18%
57IS Puritan Gray	23%

XA-Abrasive™

15XA Buckskin	23%
31XA Mayflower Red	18%
57XA Puritan Gray	23%

METRO Tread®

75T Pewter	23%
------------	-----

Down to Earth®

350 Red Paver	18%
458 Bedrock	23%
155 Cobblestone	23%
255 Desert Floor	19%

Note: Percentages based on most current data.

Installation & Specification

A typical specification to assure the use of Metropolitan Ceramics', unglazed tile on your next job should be written as follows: Ceramic tile shall be, QuarryBasics® Clear Tones, QuarryBasics® Ironspot, Down to Earth®, XA-Abrasive™, METRO Tread®, as manufactured by Metropolitan Ceramics, Canton, Ohio 44711. The body composition shall be of the finest shale and clays producing a uniformly dense body with slip-resisting texture. Color shall be: Size shall be: Patterns: As per drawing. Grout: Compatible color, as approved by architect. Test results shall be available upon request.

For best installation results, we recommend that the following be included in the specifications: Nominal 3/8" joint widths. Mix tile from several cartons for best shading during installation. Use beating block to embed tile and align surfaces and edges. Clean grout with grout sponge, cheese cloth or toweling for uniform grout color and most uniform grout level and texture. Grout joints may be damaged by some acid cleaners. Test a small area first. Wet floor with clean water before applying any acid cleaner. Do not use any product containing Hydrofluoric acid since it will attack both grout and tile. See our web site for complete downloadable specification information.

Test Results

By ANSI Standard Specification A137.1 Metropolitan Ceramics' unglazed tile is classified as quarry tile, however, the exceptional technical characteristics noted enable them to be used in virtually any application suitable for ceramic tile. Metropolitan Ceramics' unglazed tile meets the ASTM standards, the ANSI A137.1 specification for quarry tile, and Metropolitan internal requirements as listed.

Specification	Test	Standard	Result
Abrasion Resistance	ASTM C1243	Maximum Value of 275 mm ³	Metropolitan tests at < 275 mm ³
Absorption 5-hour boil	ASTM C373	Maximum 5%	Metropolitan tests at 3% maximum and qualifies as vitreous
Breaking Strength	ASTM C648	Average ≥ 275 lbf.	Metropolitan 1/2" thick tests at 800 lbf. or better.
Thickness	ASTM C499	Max. range of .050"	Metropolitan meets the standard
Nominal Size	ASTM C499	The facial dimension of each tile in the sample shall not vary more than ±2.00% from the nominal dimension.	Metropolitan meets the standard
Freeze/Thaw	ASTM C1026	Observations after 300 cycles. No visible damage.	Metropolitan meets the standard
Shear Bond Strength	ASTM C482	50 P.S.I. or better	Metropolitan exceeds the standard
DCOF Acu Test (wet)	ANSI A326.3-2017 BOT 3000	No Industry Standard.	At time of manufacture, Metropolitan XA-Abrasive™ tests at ≥0.70. All other Metropolitan products exceed 0.60.
Warpage	ASTM C485	Min. -1.5% Max. 1.5% along any edge. Min -1.0% Max 1.0% on either diagonal.	Metropolitan meets the standard
Wedging	ASTM C502	Min. -1.0% Max. 1.0%	Metropolitan meets the standard
Chemical Resistance	ASTM C650	As Reported	Class A Classification
Stain Resistance	ASTM C1378	As Reported	Metropolitan meets the standard
Scratch Hardness	MOHS	No Industry Standard	7

WARRANTY INFORMATION

Ironrock Capital, Inc., (Ironrock), warrants as limited below, that our products will meet the testing standards and specifications set forth in our current product literature. In the event of a defect or failure to conform to this written warranty, Ironrock Capital, Inc. will remedy shipment shortages and replace defective tile F.O.B. plant if timely notice of the defect is received by Ironrock prior to installation of the tile. Because specific installation details, structural design and environmental conditions are beyond Ironrock's control, we are not responsible for the performance of our products after they are installed except in the case of latent defects. Please see our web site for further details. www.metroceramics.com



USGBC
MEMBER



CE



METROPOLITAN[®]
C E R A M I C S

Ironrock Since 1866

Contact Us

www.metroceramics.com

Phone | 1.800.325.3945

Fax | 330.484.3584

Email | info@ironrock.com

P.O. BOX 9240

Canton, OH 44711