

Metropolitan Ceramics® Unglazed Ceramic Quarry Tile

Wherever food and drink is being served to the public, there needs to be a floor covering that fits the decor and performs great.

Metropolitan Ceramics products meet these needs- not only in a back-of-the-house setting- but also in the front-of-the-house where sure footing and durability are just as important. This is especially true in heavy traffic areas where moisture is common.

And with Metropolitan's Down to Earth product line, additional character has been added to the tile with popular sizes, textures, and random shading.

Metropolitan can fit with any style from traditional to contemporary while providing the most dependable ceramic tile available. And since Metropolitan is extruded and hard fired for low absorption, the design can carry from outside to indoors for continuity throughout.

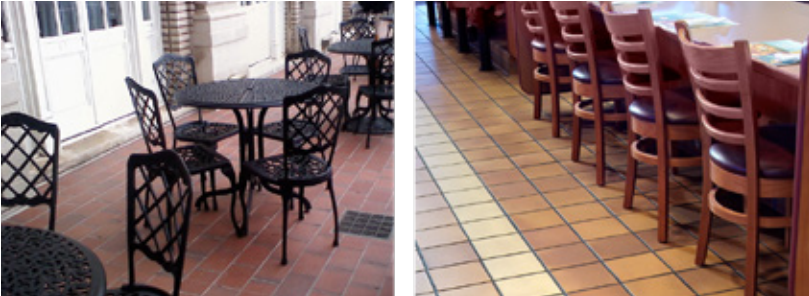

From an outdoor cafe setting shown above left to a fast paced diner above right to the bar area of a night club and casino-at right, Metropolitan has a tile that fits.



FEATURES & Benefits

- Use Indoors and Out in any Climate.
- Slip Resisting Surface.
- Extreme Durability for Heavy Traffic.
- Will not Bubble-Chip-Melt.
- Resists Grease-Bacteria-Dirty Water.
- Unglazed Surface Won't Show Wear.
- Can be Used Vertically.
- Resists Chipping and Abrasion.
- Economical.



GREEN at a Glance



VERIFIED BY
SCS Global Services

- ✓ Abundant natural resource.
- ✓ Little waste in production.
- ✓ No volatile organic compounds.
- ✓ Offering decades of performance.
- ✓ Safe to discard or repurpose.



Sizes, Colors, Textures

Sizes options include 4" x 8", 4" x 12", 6" x 9", 8" x 8" and 6" x 6". Many size options are nominal (for example, the 4" x 8" is actually 3 5/8" x 7 5/8") to allow for a grout joint when designing patterns. The most popular size 6" x 6" is (actual size). Tile thickness is 1/2". For specific applications, some products are available by special order in 3/8" and 3/4" thickness. Different size options are available in each product line. See the Metropolitan Ceramics website for complete details.

The grout joint recommended in most instances is 3/8". A 1/4" joint may sometimes be used in some instances, see web site for details. Metropolitan quarry tile is available in a variety of natural earth tones. Some products are reduction fired in the kilns to produce a random shade variation. Many colors are manufactured with little to no shade variation- for a 'single tone' appearance.

A number of products are available with texture for added appeal and to increase slip resisting properties. Details on all products manufactured by Metropolitan Ceramics are available on the Metropolitan Ceramics' website - metroceramics.com.

Trim Pieces

Metropolitan Ceramics offers a number of trim pieces. Shown below are some of the most popular trim options. Please see the Metropolitan web site - metroceramics.com for a complete listing of trim and availability.

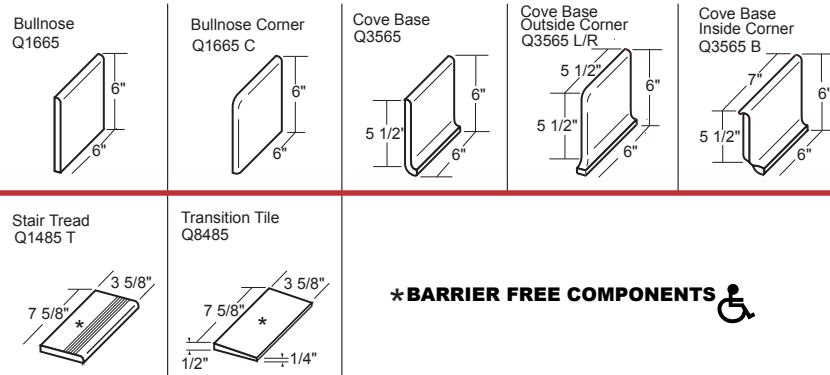

Test Results

Specification	Test	Standard	Result
Abrasion Resistance	ASTM C1243	Maximum value of 275 mm ³	Metropolitan tests at < 275 mm ³
Absorption 5-hour boil	ASTM C373	Maximum 5%	Metropolitan tests at 3% maximum and qualifies as vitreous.
Breaking Strength	ASTM C648	Average ≥ 275 lbf.	Metropolitan 1/2" thick tests at 800 lbf. or better. Metropolitan 3/8" thick tests at 400 lbf. or better.
Thickness	ASTM C499	Max. range of .050"	Metropolitan meets the standard.
Nominal Size	ASTM C499	The facial dimension of each tile in the sample shall not vary more than ±2.00% from the nominal dimension.	Metropolitan meets the standard.
Freeze/ Thaw	ASTM C1026	Observations after 300 cycles. No visible damage.	Metropolitan meets the standard.
Shear Bond Strength	ASTM C482	50 P.S.I. or better	Metropolitan exceeds the standard.
DCOF Acu Test (wet)	ANSI A326.6-2017 BOT 3000	Threshold of 0.42	At time of manufacture, Metropolitan QUARRYBASICS® XA Abrasive tests at ≥0.70. All other Metropolitan products exceed 0.60.
Warpage	ASTM C485	Min. -1.5% Max. 1.5% along any edge. Min -1.0% Max 1.0% on either diagonal.	Metropolitan meets the standard.
Wedging	ASTM C502	Min. -1.0% Max. 1.0%	Metropolitan meets the standard.
Chemical Resistance	ASTM C650	As Reported	Class A Classification
Stain Resistance	ASTM C1378	As Reported	Metropolitan meets the standard.
Scratch Hardness	MOHS	No Industry Standard	7

Added Slip Resistance

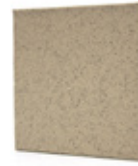

QUARRYBASICS® XA Abrasive

- Silicon Carbide Embedded Surface
- Through-the-Body Metallic Additive

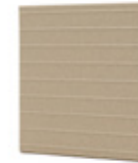

METRO TREAD®

Raised Tread Design - installed in a checkerboard pattern.

Metro Tread has the added benefit of ease of cleaning. Will not trap debris. Meets the strictest health department regulations - California - without the need for additional drains.

Environmental

For more information on Metropolitan Ceramics and LEED V4, please visit our web site - metroceramics.com.

Specifications

By ANSI Standard Specification A137.1 Metropolitan Ceramics' unglazed quarry tile is classified as quarry tile, however, the exceptional technical characteristics noted allow them to be used in virtually any application suitable for ceramic tile. Metropolitan Ceramics' unglazed tile meets both the ASTM standards, the ANSI A137.1 specification for quarry tile, and Metropolitan internal standards as listed.

Cleaning and Maintenance

Metropolitan quarry tile is easy to maintain and requires only neutral cleaners and no special power washing!

For complete specification and cleaning/maintenance information, including download versions, please visit our web site - metroceramics.com

Contact

1.800.325.3945
email: info@ironrock.com
metroceramics.com

P.O. Box 9240 Canton, OH 44711



METROPOLITAN
C E R A M I C S

Ironrock Since 1866