

# Metropolitan Ceramics® Unglazed Ceramic Quarry Tile

## Metropolitan Ceramics® Unglazed Ceramic Quarry Tile

There is no doubting the impact upgrading to ceramic tile over a concrete floor makes in the automotive sales/service market. And, the level of professionalism it adds to the space does not go unnoticed by customers. But, when using ceramic tile in this environment, durability is a must.

When considering ceramic tile for service areas, waiting areas, parts areas, showrooms, and offices, the tile needs to be able to withstand not only the weight of vehicle traffic (the average car weighs around 4,000 lbs) but also the potential of falling tools/parts and plenty of pedestrian traffic. The tile needs to be maintenance friendly and in many cases suited for indoor outdoor use.

There is one tile that meets all of these criteria and has an appealing look, natural slip resisting surface, and a variety of size and color options. That tile is Metropolitan Ceramics unglazed quarry tile.



The photo above shows Metropolitan Ceramics tile used in a service entrance. The image to the right shows Metropolitan used in a car bay area.



# Automotive Dealerships

## FEATURES & Benefits

- Use Indoors and Out in any Climate.
- Slip Resisting Surface.
- Extreme Durability for Heavy Traffic.
- Will not Bubble-Chip-Melt.
- Resists Grease-Bacteria-Dirty Water.
- Unglazed Surface Won't Show Wear.
- Can be Used Vertically.
- Resists Chipping and Abrasion.
- Economical.



## GREEN at a Glance



- ✓ Abundant natural resource.
- ✓ Little waste in production.
- ✓ No volatile organic compounds.
- ✓ Offering decades of performance.
- ✓ Safe to discard or repurpose.



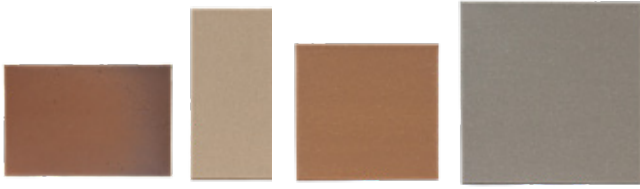

## Sizes, Colors, Textures

Sizes options include 4" x 8", 4" x 12", 6" x 9", 8" x 8" and 6" x 6". Many size options are nominal (for example, the 4" x 8" is actually 3 5/8" x 7 5/8") to allow for a grout joint when designing patterns. The most popular size 6" x 6" is (actual size). Tile thickness is 1/2". For specific applications, some products are available by special order in 3/8" and 3/4" thickness. Different size options are available in each product line. See the Metropolitan Ceramics website for complete details.

The grout joint recommended in most instances is 3/8". A 1/4" joint may sometimes be used in some instances, see web site for details. Metropolitan quarry tile is available in a variety of natural earth tones. Some products are reduction fired in the kilns to produce a random shade variation. Many colors are manufactured with little to no shade variation- for a 'single tone' appearance.

A number of products are available with texture for added appeal and to increase slip resisting properties. Details on all products manufactured by Metropolitan Ceramics are available on the Metropolitan Ceramics' website - metroceramics.com.

## Trim Pieces

Metropolitan Ceramics offers a number of trim pieces. Shown below are some of the most popular trim options. Please see the Metropolitan web site - metroceramics.com for a complete listing of trim and availability.

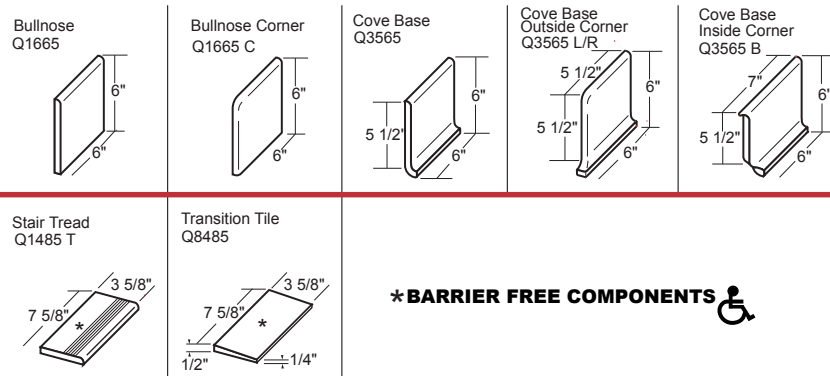

\*BARRIER FREE COMPONENTS

## Test Results

Specification	Test	Standard	Result
Abrasion Resistance	ASTM C1243	Maximum value of 275 mm <sup>3</sup>	Metropolitan tests at < 275 mm <sup>3</sup>
Absorption 5-hour boil	ASTM C373	Maximum 5%	Metropolitan tests at 3% maximum and qualifies as vitreous.
Breaking Strength	ASTM C648	Average ≥ 275 lbf.	Metropolitan 1/2" thick tests at 800 lbf. or better. Metropolitan 3/8" thick tests at 400 lbf. or better.
Thickness	ASTM C499	Max. range of .050"	Metropolitan meets the standard.
Nominal Size	ASTM C499	The facial dimension of each tile in the sample shall not vary more than ±2.00% from the nominal dimension.	Metropolitan meets the standard.
Freeze/ Thaw	ASTM C1026	Observations after 300 cycles. No visible damage.	Metropolitan meets the standard.
Shear Bond Strength	ASTM C482	50 P.S.I. or better	Metropolitan exceeds the standard.
DCOF Acu Test (wet)	ANSI A326.3-2017 BOT 3000	Threshold of 0.42	At time of manufacture, Metropolitan QUARRYBASICS® XA Abrasive tests at ≥0.70. All other Metropolitan products exceed 0.60.
Warpage	ASTM C485	Min. -1.5% Max. 1.5% along any edge. Min -1.0% Max 1.0% on either diagonal.	Metropolitan meets the standard.
Wedging	ASTM C502	Min. -1.0% Max. 1.0%	Metropolitan meets the standard.
Chemical Resistance	ASTM C650	As Reported	Class A Classification
Stain Resistance	ASTM C1378	As Reported	Metropolitan meets the standard.
Scratch Hardness	MOHS	No Industry Standard	7

## Added Slip Resistance

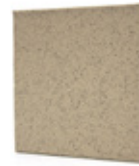

### QUARRYBASICS® XA Abrasive

- Silicon Carbide Embedded Surface
- Through-the-Body Metallic Additive

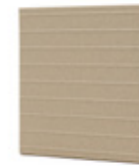

### METRO TREAD®

Raised Tread Design - installed in a checkerboard pattern.

*Metro Tread has the added benefit of ease of cleaning. Will not trap debris. Meets the strictest health department regulations - California - without the need for additional drains.*

## Environmental

For more information on Metropolitan Ceramics and LEED V4, please visit our web site - metroceramics.com.

## Specifications

By ANSI Standard Specification A137.1 Metropolitan Ceramics' unglazed quarry tile is classified as quarry tile, however, the exceptional technical characteristics noted allow them to be used in virtually any application suitable for ceramic tile. Metropolitan Ceramics' unglazed tile meets both the ASTM standards, the ANSI A137.1 specification for quarry tile, and Metropolitan internal standards as listed.

## Cleaning and Maintenance

Metropolitan quarry tile is easy to maintain and requires only neutral cleaners and no special power washing!

For complete specification and cleaning/maintenance information, including download versions, please visit our web site - metroceramics.com

## Contact

1.800.325.3945  
email: info@ironrock.com  
metroceramics.com  
P.O. Box 9240 Canton, OH 44711



**METROPOLITAN**  
C E R A M I C S

*Ironrock Since 1866*

MET\_VM\_1020